

FCC Test Report

Report No.: FDBDBO-WTW-P20070114

Test Model: GPC-1000

Series Model: GPC-1XXXXXXXXXXXXXXXXXXXXXXXXXXXX
("X" can be 0-9, A-Z or blank for marketing purpose)

Received Date: Jul. 7, 2020

Test Date: Sep. 1 to 2, 2020

Issued Date: Sep. 23, 2020

Applicant: Vecow Co., Ltd.

Address: 3F., No.10, Jiankang Rd., Zhonghe Dist., New Taipei City 23586, Taiwan

Issued By: Bureau Veritas Consumer Products Services (H.K.) Ltd., Taoyuan Branch
Lin Kou Laboratories

Lab Address: No. 47-2, 14th Ling, Chia Pau Vil., Lin Kou Dist., New Taipei City, Taiwan

**FCC Registration /
Designation Number:** 418586 / TW1078



This report is for your exclusive use. Any copying or replication of this report to or for any other person or entity, or use of our name or trademark, is permitted only with our prior written permission. This report sets forth our findings solely with respect to the test samples identified herein. The results set forth in this report are not indicative or representative of the quality or characteristics of the lot from which a test sample was taken or any similar or identical product unless specifically and expressly noted. Our report includes all of the tests requested by you and the results thereof based upon the information that you provided to us. You have 60 days from date of issuance of this report to notify us of any material error or omission caused by our negligence, provided, however, that such notice shall be in writing and shall specifically address the issue you wish to raise. A failure to raise such issue within the prescribed time shall constitute your unqualified acceptance of the completeness of this report, the tests conducted and the correctness of the report contents. Unless specific mention, the uncertainty of measurement has been explicitly taken into account to declare the compliance or non-compliance to the specification.

Table of Contents

Release Control Record	3
1 Certificate of Conformity	4
2 Summary of Test Results	5
2.1 Measurement Uncertainty	5
2.2 Modification Record	5
3 General Information	6
3.1 Description of EUT	6
3.2 Features of EUT	6
3.3 Operating Modes of EUT and Determination of Worst Case Operating Mode	7
3.4 Test Program Used and Operation Descriptions.....	7
3.5 Primary Clock Frequencies of Internal Source	7
4 Configuration and Connections with EUT	8
4.1 Connection Diagram of EUT and Peripheral Devices	8
4.2 Configuration of Peripheral Devices and Cable Connections	9
5 Conducted Emissions at Mains Ports	10
5.1 Limits	10
5.2 Test Instruments	10
5.3 Test Arrangement	11
5.4 Test Results.....	12
6 Radiated Emissions up to 1 GHz	14
6.1 Limits	14
6.2 Test Instruments	14
6.3 Test Arrangement	15
6.4 Test Results.....	16
7 Radiated Emissions above 1 GHz	18
7.1 Limits	18
7.2 Test Instruments	19
7.3 Test Arrangement	20
7.4 Test Results.....	21
8 Pictures of Test Arrangements	23
8.1 Conducted Emissions at Mains Ports	23
8.2 Radiated Emissions up to 1 GHz	24
8.3 Radiated Emissions above 1 GHz	25
Appendix – Information of the Testing Laboratories	26

Release Control Record

Issue No.	Description	Date Issued
FDBDBO-WTW-P20070114	Original release.	Sep. 23, 2020

1 Certificate of Conformity

Product: GPC-1000 Series

Brand: Vecow

Test Model: GPC-1000

Series Model: GPC-1XXXXXXXXXXXXXXXXXXXXXXXXXXXX
("X" can be 0-9, A-Z or blank for marketing purpose)

Sample Status: Engineering sample

Applicant: Vecow Co., Ltd.

Test Date: Sep. 1 to 2, 2020

Standards: 47 CFR FCC Part 15, Subpart B, Class A
ICES-003: 2016 Issue 6, updated Apr. 2019 Class A
ANSI C63.4:2014

The above equipment has been tested by **Bureau Veritas Consumer Products Services (H.K.) Ltd., Taoyuan Branch**, and found compliance with the requirement of the above standards. The test record, data evaluation & Equipment Under Test (EUT) configurations represented herein are true and accurate accounts of the measurements of the sample's EMC characteristics under the conditions specified in this report.

Prepared by :  , **Date:** Sep. 23, 2020
Vivian Chen / Specialist

Approved by :  , **Date:** Sep. 23, 2020
Jim Hsiang / Associate Technical Manager

2 Summary of Test Results

47 CFR FCC Part 15, Subpart B / ICES-003: 2016 Issue 6, updated Apr. 2019 Class A

ANSI C63.4:2014

FCC Clause	ICES-003 Clause	Test Item	Result/Remarks	Verdict
15.107	6.1	Conducted Emissions at mains ports	Minimum passing Class A margin is -18.35 dB at 2.57292 MHz	Pass
15.109	6.2.1	Radiated Emissions up to 1 GHz	Minimum passing Class A margin is -2.20 dB at 923.99 MHz	Pass
	6.2.2	Radiated Emissions above 1 GHz	Minimum passing Class A margin is -7.66 dB at 1541.52 MHz	Pass

Note:

1. There is no deviation to the applied test methods and requirements covered by the scope of this report.
2. Determining compliance based on the results of the compliance measurement, not taking into account measurement instrumentation uncertainty

2.1 Measurement Uncertainty

Where relevant, the following measurement uncertainty levels have been estimated for tests performed on the EUT:

Measurement	Frequency	Expanded Uncertainty (k=2) (\pm)
Conducted Emissions at mains ports	150kHz ~ 30MHz	2.94 dB
Radiated Emissions up to 1 GHz	30MHz ~ 1GHz	4.30 dB
Radiated Emissions above 1 GHz	1GHz ~ 6GHz	4.96 dB

2.2 Modification Record

There were no modifications required for compliance.

3 General Information

3.1 Description of EUT

Product	GPC-1000 Series
Brand	Vecow
Test Model	GPC-1000
Series Model	GPC-1XXXXXXXXXXXXXXXXXXXXXXXXXXXX ("X" can be 0-9, A-Z or blank for marketing purpose)
Model Difference	For marketing purpose
Sample Status	Engineering sample
Operating Software	Windows 10, Burnintest
Power Supply Rating	DC from Adapter
Accessory Device	N/A
Data Cable Supplied	N/A

3.2 Features of EUT

- The tests reported herein were performed according to the method specified by Vecow Co., Ltd., for detailed feature description, please refer to the manufacturer's specifications or user's manual.
- The EUT was configured with the following key components:

Components	Brand	Model	Specification
CPU	Intel	i7-8700	3.2GHz
RAM	DSL	-	DDR4 2666 16GB
SSD	Innodisk	3MR3-P	64GB 2080 *2PCS
Motherboard	Vecow	EXBC-1XXXXXXXX Series	-
Power Module	Vecow	WPM-120	-

- The client provided the following adapters for the test:

Adapter	Brand	Model	Rating
Adapter 1	L.T.E.	LTE36E-S2-1	AC I/P: 100-240Vac, 0.75A, 50/60Hz DC O/P: 12V, 3A, 36W max Non-shielded AC 3Pin (1.7m) Non-shielded DC (1.0m)
Adapter 2	FSP	FSP120-AABN2	AC I/P: 100-240Vac, 1.8A, 50-60Hz DC O/P: 24V, 5.0A Max, 120W Max. Non-shielded AC 3Pin (1.55m) Non-shielded DC (1.8m) with one ferrite core.

3.3 Operating Modes of EUT and Determination of Worst Case Operating Mode

Test modes are presented in the report as below.

Mode	Test Condition	Input Power
Conducted emission & Radiated emission tests		
1	Full system (DP: 3840*2160, 60Hz + DVI: 1920*1080, 60Hz)	120Vac/ 60Hz

3.4 Test Program Used and Operation Descriptions

- a. Turned on the power of all equipment.
- b. EUT ran a test program to enable all functions.
- c. EUT read and wrote messages from/to SSD and ext. HDD.
- d. EUT sent and received messages to/from Notebook PCs (kept in a remote area) via four UTP LAN cables (10m each).
- e. EUT sent "H" messages to ext. LCD Monitors. Then they displayed "H" messages on their screens simultaneously.
- f. EUT sent "1kHz" audio signal to earphone.
- g. EUT sent messages to printer and printer printed them out.
- h. Steps c-g were repeated.

3.5 Primary Clock Frequencies of Internal Source

The highest frequency generated or used within the EUT or on which the EUT operates or tunes is 3.2GHz, provided by Vecow Co., Ltd., for detailed internal source, please refer to the manufacturer's specifications.

4 Configuration and Connections with EUT

4.1 Connection Diagram of EUT and Peripheral Devices

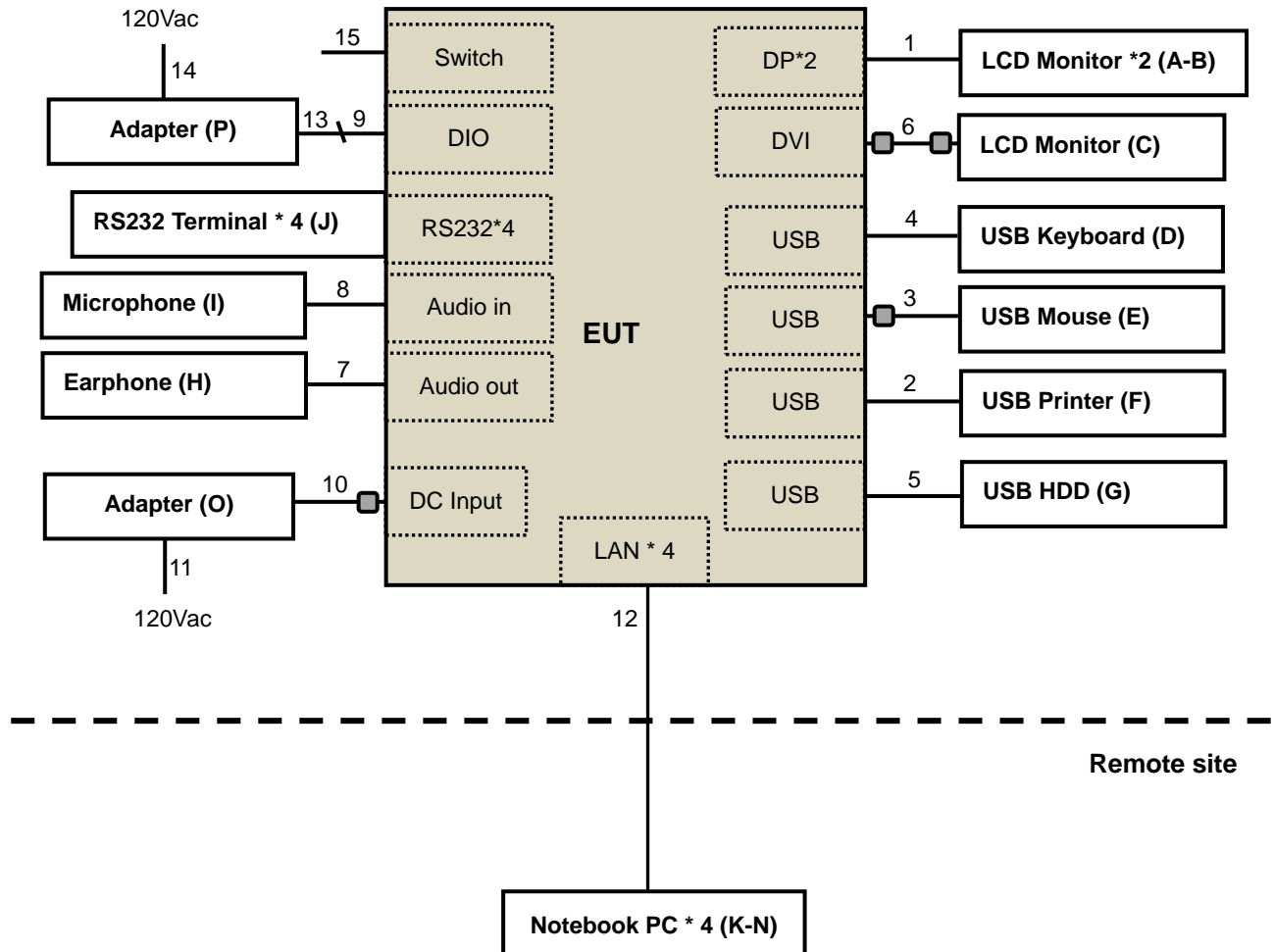

4.2 Configuration of Peripheral Devices and Cable Connections

ID	Product	Brand	Model No.	Serial No.	FCC ID	Remarks
A.	LCD Monitor	ASUS	MG28UQ	J1LMTF114792	NA	Provided by Lab
B.	LCD Monitor	ASUS	MG28UQ	HCLMTF053714	NA	Provided by Lab
C.	24 LCD MONITOR"	DELL	U2410	CN082WXD728720C C0LGL	FCC DoC Approved	Provided by Lab
D.	USB Keyboard	Dell	KB216t	CN-0W33XP-LO300- 7CL-1918	NA	Provided by Lab
E.	USB Mouse	Microsoft	1113	9170528318308	FCC DoC Approved	Provided by Lab
F.	USB Printer	HP	HP Officejet Pro 251dw	CN55FCV012	FCC DoC Approved	Provided by Lab
G.	External Hard Disk	Plextor	EX1-128	P02643115586	NA	Provided by Lab
H.	EARPHONE	PHILIPS	SBC HL150	H2010155	NA	Provided by Lab
I.	MICROPHONE	Labtec	mic-333	N/A	NA	Provided by Lab
J.	RS232 Terminal* 4	N/A	NA	N/A	NA	Provided by Lab
K.	Notebook PC	DELL	P41G	GT4W952	NA	Provided by Lab
L.	Notebook PC	SONY	SVS151A12P	275548477001024	NA	Provided by Lab
M.	Notebook PC	ASUS	PU401L	ECNXBC012528528	NA	Provided by Lab
N.	Notebook PC	DELL	P41G	FT4W952	FCC DoC Approved	Provided by Lab
O.	Adapter	FSP	FSP120-AABN2	NA	NA	Supplied by client
P.	Adapter	L.T.E.	LTE36E-S2-1	NA	NA	Supplied by client

Note:

1. All power cords of the above support units are non-shielded (1.8m).
2. Items K-N acted as communication partners to transfer data.

ID	Cable Descriptions	Qty.	Length (m)	Shielding (Yes/No)	Cores (Qty.)	Remarks
1.	DP cable	2	1.8	Y	0	Provided by Lab
2.	USB cable	1	1.8	Y	0	Provided by Lab
3.	USB cable	1	1.8	Y	1	Provided by Lab
4.	USB cable	1	1.8	Y	0	Provided by Lab
5.	USB cable	1	0.5	Y	0	Provided by Lab
6.	DVI cable	1	1.8	Y	2	Provided by Lab
7.	Audio cable	1	1.2	N	0	Provided by Lab
8.	Audio cable	1	2.5	N	0	Provided by Lab
9.	DIO cable	1	3.0	N	0	Provided by Lab
10.	DC cable	1	1.8	N	1	Supplied by client
11.	AC cable	1	1.55	N	0	Supplied by client
12.	LAN cable	4	10	N	0	Provided by Lab (RJ45, Cat.5e)
13.	DC cable	1	1.0	N	0	Supplied by client
14.	AC cable	1	1.7	N	0	Supplied by client
15.	Switch cable	1	0.36	N	0	Supplied by client

Note: The core(s) is(are) originally attached to the cable(s).

5 Conducted Emissions at Mains Ports

5.1 Limits

Frequency (MHz)	Class A (dBUV)		Class B (dBUV)	
	Quasi-peak	Average	Quasi-peak	Average
0.15 - 0.5	79	66	66 - 56	56 - 46
0.50 - 5.0	73	60	56	46
5.0 - 30.0	73	60	60	50

Notes: 1. The lower limit shall apply at the transition frequencies.
 2. The limit decreases linearly with the logarithm of the frequency in the range of 0.15 to 0.50 MHz.

5.2 Test Instruments

Description & Manufacturer	Model No.	Serial No.	Cal. Date	Cal. Due
ROHDE & SCHWARZ TEST RECEIVER	ESR3	102413	Feb. 17, 2020	Feb. 16, 2021
ROHDE & SCHWARZ Artificial Mains Network (for EUT)	ESH2-Z5	100104	Dec. 13, 2019	Dec. 12, 2020
LISN With Adapter (for EUT)	AD10	C09Ada-001	Dec. 13, 2019	Dec. 12, 2020
ROHDE & SCHWARZ Artificial Mains Network (for peripherals)	ESH3-Z5	847265/023	Oct. 31, 2019	Oct. 30, 2020
SCHWARZBECK Artificial Mains Network (For EUT)	NNLK8129	8129229	May 14, 2020	May 13, 2021
SCHWARZBECK Artificial Mains Network (for EUT)	NNLK 8121	8121-808	Apr. 10, 2020	Apr. 9, 2021
Software	Cond_V7.3.7.4	NA	NA	NA
RF cable (JYEBAO) With 10dB PAD	5D-FB	Cable-C09.01	Aug. 14, 2020	Aug. 13, 2021
SUHNER Terminator (For ROHDE & SCHWARZ LISN)	65BNC-5001	E1-010789	May 13, 2020	May 12, 2021

Note: 1. The calibration interval of the above test instruments is 12 months and the calibrations are traceable to NML/ROC and NIST/USA.
 2. The test was performed in Shielded Room No. 9. (Conduction 9)
 3. The VCCI Site Registration No. C-11312.
 4. Tested Date: Sep. 1, 2020

5.3 Test Arrangement

- The EUT was placed 0.4 meters from the conducting wall of the shielded room with EUT being connected to the power mains through a line impedance stabilization network (LISN). Other support units were connected to the power mains through another LISN. The two LISNs provide 50 Ohm/ 50uH of coupling impedance for the measuring instrument.
- Both lines of the power mains connected to the EUT were checked for maximum conducted interference.
- The test results of conducted emissions at mains ports are recorded of six worst margins for quasi-peak (mandatory) [and average (if necessary)] values against the limits at frequencies of interest unless the margin is 20 dB or greater.

Note: The resolution bandwidth and video bandwidth of test receiver is 9kHz for quasi-peak detection (QP) and average detection (AV) at frequency 0.15MHz-30MHz.

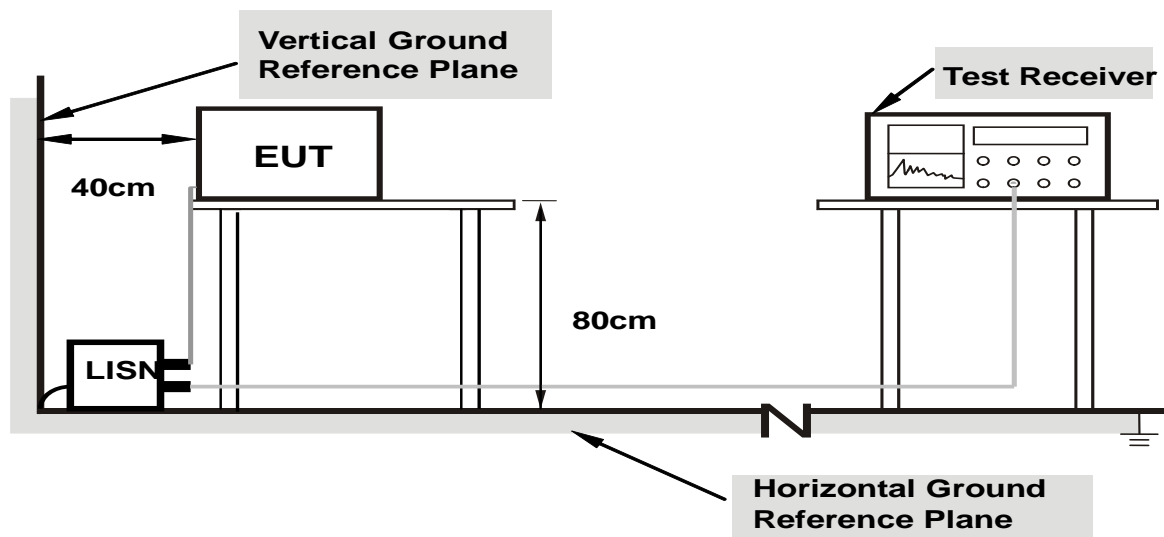

Note: Support units were connected to second LISN.

For the actual test configuration, please refer to the related item – Photographs of the Test Configuration.

5.4 Test Results

Frequency Range	150kHz ~ 30MHz	Detector Function & Resolution Bandwidth	Quasi-Peak (QP) / Average (AV), 9kHz
Input Power	120Vac, 60Hz	Environmental Conditions	24°C, 71%RH
Tested by	Borg Wang	Test Date	2020/9/1
Test Mode	Mode 1		

Phase Of Power : Line (L)										
No	Frequency (MHz)	Correction Factor (dB)	Reading Value (dBuV)		Emission Level (dBuV)		Limit (dBuV)		Margin (dB)	
			Q.P.	AV.	Q.P.	AV.	Q.P.	AV.	Q.P.	AV.
1	0.16526	10.18	38.95	30.16	49.13	40.34	79.00	66.00	-29.87	-25.66
2	1.28611	10.27	30.28	24.28	40.55	34.55	73.00	60.00	-32.45	-25.45
3	2.57392	10.36	31.94	30.84	42.30	41.20	73.00	60.00	-30.70	-18.80
4	12.50912	10.79	28.89	23.18	39.68	33.97	73.00	60.00	-33.32	-26.03
5	16.92855	11.00	29.66	23.02	40.66	34.02	73.00	60.00	-32.34	-25.98
6	22.15365	11.15	28.52	21.47	39.67	32.62	73.00	60.00	-33.33	-27.38

Remarks:

1. Q.P. and AV. are abbreviations of quasi-peak and average individually.
2. The emission levels of other frequencies were very low against the limit.
3. Margin value = Emission level – Limit value
4. Correction factor = Insertion loss + Cable loss
5. Emission Level = Correction Factor + Reading Value

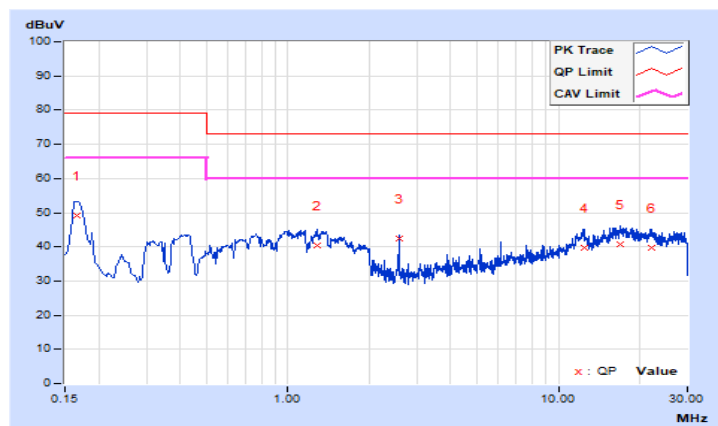

Frequency Range	150kHz ~ 30MHz	Detector Function & Resolution Bandwidth	Quasi-Peak (QP) / Average (AV), 9kHz
Input Power	120Vac, 60Hz	Environmental Conditions	24°C, 71%RH
Tested by	Borg Wang	Test Date	2020/9/1
Test Mode	Mode 1		

Phase Of Power : Neutral (N)										
No	Frequency (MHz)	Correction Factor (dB)	Reading Value (dBuV)		Emission Level (dBuV)		Limit (dBuV)		Margin (dB)	
			Q.P.	AV.	Q.P.	AV.	Q.P.	AV.	Q.P.	AV.
1	0.15882	10.16	34.33	23.61	44.49	33.77	79.00	66.00	-34.51	-32.23
2	0.38466	10.19	33.59	24.15	43.78	34.34	79.00	66.00	-35.22	-31.66
3	1.08665	10.25	33.05	24.21	43.30	34.46	73.00	60.00	-29.70	-25.54
4	1.28447	10.26	32.63	25.71	42.89	35.97	73.00	60.00	-30.11	-24.03
5	2.57292	10.35	33.69	31.30	44.04	41.65	73.00	60.00	-28.96	-18.35
6	18.62983	10.89	28.97	22.38	39.86	33.27	73.00	60.00	-33.14	-26.73

Remarks:

1. Q.P. and AV. are abbreviations of quasi-peak and average individually.
2. The emission levels of other frequencies were very low against the limit.
3. Margin value = Emission level – Limit value
4. Correction factor = Insertion loss + Cable loss
5. Emission Level = Correction Factor + Reading Value

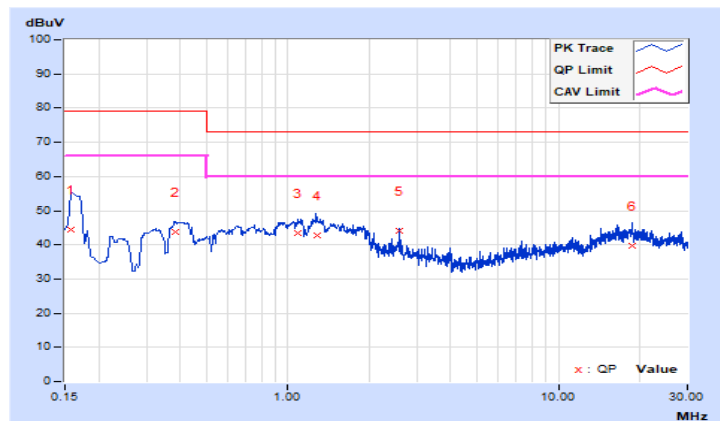

6 Radiated Emissions up to 1 GHz

6.1 Limits

Emissions radiated outside of the specified bands, shall be according to the general radiated limits as following:

Radiated Emissions Limits at 10 meters (dB μ V/m)				
Frequencies (MHz)	FCC 15B / ICES-003, Class A	FCC 15B / ICES-003, Class B	CISPR 22, Class A	CISPR 22, Class B
30-88	39	29.5	40	30
88-216	43.5	33.1		
216-230	46.4	35.6		
230-960			47	37
960-1000	49.5	43.5		

Radiated Emissions Limits at 3 meters (dB μ V/m)				
Frequencies (MHz)	FCC 15B / ICES-003, Class A	FCC 15B / ICES-003, Class B	CISPR 22, Class A	CISPR 22, Class B
30-88	49.5	40	50.5	40.5
88-216	54	43.5		
216-230	56.9	46		
230-960			57.5	47.5
960-1000	60	54		

- Notes: 1. The lower limit shall apply at the transition frequencies.
 2. Emission level (dB μ V/m) = 20 log Emission level (uV/m).
 3. QP detector shall be applied if not specified.

6.2 Test Instruments

Description & Manufacturer	Model No.	Serial No.	Cal. Date	Cal. Due
ROHDE & SCHWARZ TEST RECEIVER	ESCS 30	100027	May 19, 2020	May 18, 2021
Schwarzbeck Bilog Antenna	VULB9168	9168-303	Nov. 11, 2019	Nov. 10, 2020
Agilent Preamplifier	8447D	2944A08119	Feb. 19, 2020	Feb. 18, 2021
ADT. Turn Table	TT100	0205	NA	NA
ADT. Tower	AT100	0205	NA	NA
Software	Radiated_V7.6.15.9.5	NA	NA	NA
ADT RF Switches BOX	EMH-011	1001	Oct. 24, 2019	Oct. 23, 2020
Pacific RF cable With 5dB PAD	8D	CABLE-ST2-01	Oct. 24, 2019	Oct. 23, 2020

- Note: 1. The calibration interval of the above test instruments is 12 months and the calibrations are traceable to NML/ROC and NIST/USA.
 2. The test was performed in Open Site No. 2.
 3. The VCCI Site Registration No. R-10237.
 4. Tested Date: Sep. 2, 2020

6.3 Test Arrangement

- The EUT was placed on the top of a rotating table 0.8 meters above the ground at an accredited test facility. The table was rotated 360 degrees to determine the position of the highest radiation.
- The EUT was set 10 meters away from the interference-receiving antenna, which was mounted on the top of a variable-height antenna tower.
- The antenna is a broadband antenna, and its height is varied from one meter to four meters above the ground to determine the maximum value of the field strength. Both horizontal and vertical polarizations of the antenna are set to make the measurement.
- For each suspected emission, the EUT was arranged to its worst case and then the antenna was tuned to heights from 1 meter to 4 meters and the rotatable table was turned from 0 degrees to 360 degrees to find the maximum reading.
- The test-receiver system was set to quasi-peak detect function and specified bandwidth with maximum hold mode when the test frequency is up to 1 GHz.

Note: The resolution bandwidth and video bandwidth of test receiver/spectrum analyzer is 120kHz for quasi-peak detection (QP) at frequency up to 1GHz.

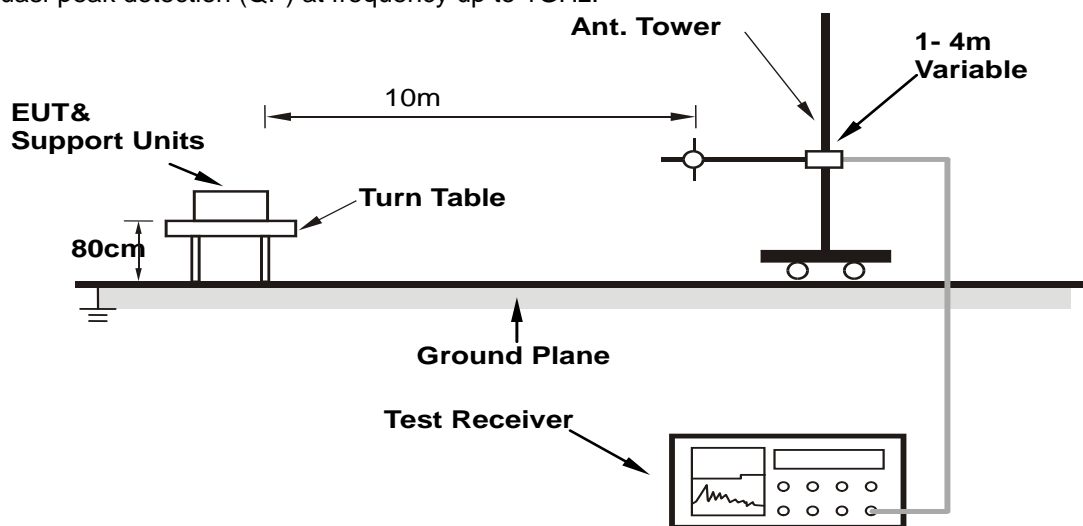

For the actual test configuration, please refer to the related item – Photographs of the Test Configuration.

6.4 Test Results

Frequency Range	30MHz ~ 1GHz	Detector Function & Resolution Bandwidth	Quasi-Peak (QP), 120kHz
Input Power	120Vac, 60Hz	Environmental Conditions	33°C, 60%RH
Tested By	Vhenson Huang	Test Date	2020/9/2
Test Mode	Mode 1		

Antenna Polarity & Test Distance : Horizontal at 10 m

No	Frequency (MHz)	Emission Level (dBuV/m)	Limit (dBuV/m)	Margin (dB)	Antenna Height (m)	Table Angle (Degree)	Raw Value (dBuV)	Correction Factor (dB/m)
1	65.23	33.25 QP	40.00	-6.75	4.00 H	140	44.57	-11.32
2	141.02	31.79 QP	40.00	-8.21	4.00 H	37	41.48	-9.69
3	154.02	33.48 QP	40.00	-6.52	4.00 H	105	42.53	-9.05
4	171.50	31.95 QP	40.00	-8.05	4.00 H	211	41.54	-9.59
5	196.26	33.16 QP	40.00	-6.84	4.00 H	273	45.38	-12.22
6	308.00	35.44 QP	47.00	-11.56	3.12 H	312	42.83	-7.39
7	462.01	43.60 QP	47.00	-3.40	1.96 H	268	47.63	-4.03
8	616.01	41.79 QP	47.00	-5.21	1.52 H	211	42.52	-0.73
9	701.56	42.15 QP	47.00	-4.85	1.22 H	190	41.17	0.98
10	729.12	42.96 QP	47.00	-4.04	1.00 H	30	41.52	1.44
11	923.99	44.80 QP	47.00	-2.20	1.00 H	113	39.29	5.51
12	992.50	38.80 QP	47.00	-8.20	1.06 H	270	32.62	6.18

Remarks:

1. Emission Level(dBuV/m) = Raw Value(dBuV) + Correction Factor(dB/m)
2. Correction Factor(dB/m) = Antenna Factor (dB/m) + Cable Factor (dB) – Pre-Amplifier Factor (dB)
3. The other emission levels were very low against the limit.
4. Margin value = Emission level – Limit value

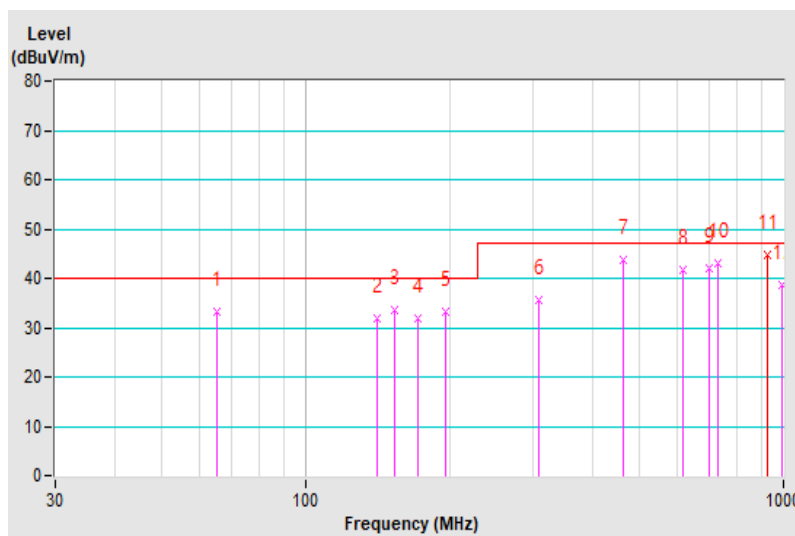

Frequency Range	30MHz ~ 1GHz	Detector Function & Resolution Bandwidth	Quasi-Peak (QP), 120kHz
Input Power	120Vac, 60Hz	Environmental Conditions	33°C, 60%RH
Tested By	Vhenson Huang	Test Date	2020/9/2
Test Mode	Mode 1		

Antenna Polarity & Test Distance : Vertical at 10 m								
No	Frequency (MHz)	Emission Level (dBuV/m)	Limit (dBuV/m)	Margin (dB)	Antenna Height (m)	Table Angle (Degree)	Raw Value (dBuV)	Correction Factor (dB/m)
1	30.45	35.59 QP	40.00	-4.41	1.68 V	41	47.08	-11.49
2	45.66	32.93 QP	40.00	-7.07	1.32 V	150	42.69	-9.76
3	65.06	37.46 QP	40.00	-2.54	1.00 V	223	48.78	-11.32
4	87.56	31.96 QP	40.00	-8.04	1.58 V	85	47.57	-15.61
5	110.75	30.59 QP	40.00	-9.41	1.00 V	122	43.20	-12.61
6	154.02	34.69 QP	40.00	-5.31	1.00 V	260	43.74	-9.05
7	195.63	30.89 QP	40.00	-9.11	1.00 V	95	43.08	-12.19
8	308.01	34.30 QP	47.00	-12.70	1.00 V	181	41.69	-7.39
9	462.00	40.17 QP	47.00	-6.83	1.00 V	210	44.20	-4.03
10	616.00	42.97 QP	47.00	-4.03	2.61 V	265	43.70	-0.73
11	701.51	40.94 QP	47.00	-6.06	2.82 V	107	39.96	0.98
12	924.01	43.76 QP	47.00	-3.24	2.35 V	58	38.25	5.51

Remarks:

1. Emission Level(dBuV/m) = Raw Value(dBuV) + Correction Factor(dB/m)
2. Correction Factor(dB/m) = Antenna Factor (dB/m) + Cable Factor (dB) – Pre-Amplifier Factor (dB)
3. The other emission levels were very low against the limit.
4. Margin value = Emission level – Limit value

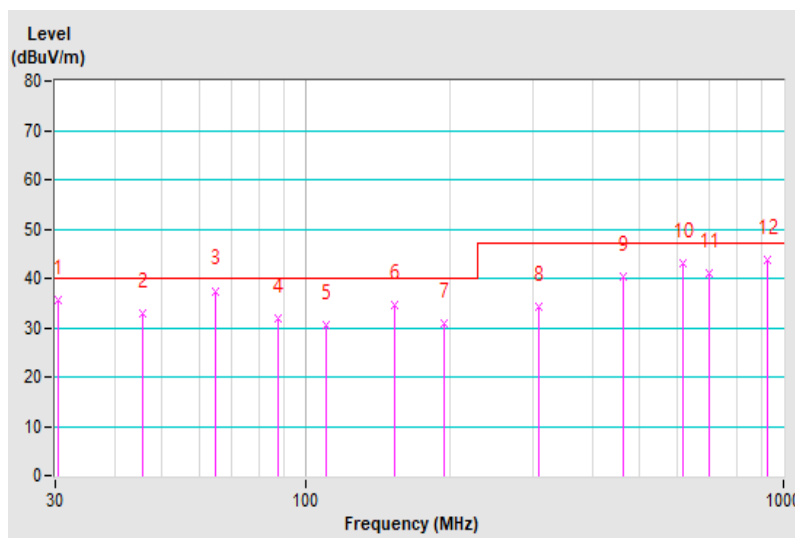

7 Radiated Emissions above 1 GHz

7.1 Limits

Emissions radiated outside of the specified bands, shall be according to the general radiated limits as following:

Radiated Emissions Limits at 10 meters (dB μ V/m)				
Frequencies (MHz)	FCC 15B / ICES-003, Class A	FCC 15B / ICES-003, Class B	CISPR 22, Class A	CISPR 22, Class B
1000-3000	Avg: 49.5	Avg: 43.5	Not defined	Not defined
Above 3000	Peak: 69.5	Peak: 63.5	Not defined	Not defined

Radiated Emissions Limits at 3 meters (dB μ V/m)				
Frequencies (MHz)	FCC 15B / ICES-003, Class A	FCC 15B / ICES-003, Class B	CISPR 22, Class A	CISPR 22, Class B
1000-3000	Avg: 60	Avg: 54	Avg: 56 Peak: 76	Avg: 50 Peak: 70
Above 3000	Peak: 80	Peak: 74	Avg: 60 Peak: 80	Avg: 54 Peak: 74

- Notes: 1. The lower limit shall apply at the transition frequencies.
 2. Emission level (dB μ V/m) = 20 log Emission level (uV/m).
 3. As shown in 15.35(b), for frequencies above 1000MHz, the field strength limits are based on average detector, however, the peak field strength of any emission shall not exceed the maximum permitted average limits, specified above by more than 20dB under any condition of modulation.

Frequency Range (For unintentional radiators)

Highest frequency generated or used in the device or on which the device operates or tunes (MHz)	Upper frequency of measurement range (MHz)
Below 1.705	30
1.705-108	1000
108-500	2000
500-1000	5000
Above 1000	5th harmonic of the highest frequency or 40GHz, whichever is lower

7.2 Test Instruments

Description & Manufacturer	Model No.	Serial No.	Cal. Date	Cal. Due
Agilent Spectrum	E4446A	MY51100009	Jun. 23, 2020	Jun. 22, 2021
Agilent Test Receiver	N9038A	MY50010135	May 29, 2020	May 28, 2021
EMCI Preamplifier	EMC0126545	980076	Feb. 20, 2020	Feb. 19, 2021
MITEQ Preamplifier	AMF-6F-260400-33-8P	892164	Feb. 20, 2020	Feb. 19, 2021
EMCI Preamplifier	EMC184045B	980235	Feb. 20, 2020	Feb. 19, 2021
ETS Preamplifier	3117-PA	00215857	Nov. 24, 2019	Nov. 23, 2020
Schwarzbeck Horn Antenna	BBHA-9170	212	Nov. 24, 2019	Nov. 23, 2020
EMCO Horn Antenna	3115	9312-4192	Nov. 24, 2019	Nov. 23, 2020
Max Full. Turn Table & Tower	MF7802	MF780208103	NA	NA
Software	Radiated_V8.7.08	NA	NA	NA
SUHNER RF cable With 3/4dB PAD	SF102	Cable-CH7-3.6m	Jul. 9, 2020	Jul. 8, 2021
MICRO-TRONICS Notch filter	BRC50703-01	010	May 29, 2020	May 28, 2021
MICRO-TRONICS Band Pass Filter	BRM17690	005	May 29, 2020	May 28, 2021

- Note:
1. The calibration interval of the above test instruments is 12 months and the calibrations are traceable to NML/ROC and NIST/USA.
 2. The test was performed in Chamber No. 7.
 3. The VCCI Site Registration No. G-10039
 4. Tested Date: Sep. 2, 2020

7.3 Test Arrangement

- The EUT was placed on the top of a rotating table 0.8 meters above the ground at an accredited chamber room. The table was rotated 360 degrees to determine the position of the highest radiation.
- The EUT was set 3 meters away from the interference-receiving antenna, which was mounted on the top of a variable-height antenna tower.
- The height of antenna can be varied from one meter to four meters, the height of adjustment depends on the EUT height and the antenna 3dB beamwidth both, to detect the maximum value of the field strength. Both horizontal and vertical polarizations of the antenna are set to make the measurement.
- For each suspected emission, the EUT was arranged to its worst case and then the antenna was tuned to heights and the rotatable table was turned from 0 degrees to 360 degrees to find the maximum reading.
- The spectrum analyzer system was set to peak and average detect function and specified bandwidth with maximum hold mode when the test frequency is above 1 GHz.

Note: The resolution bandwidth of test receiver/spectrum analyzer is 1MHz and video bandwidth is 3MHz for Peak detection (PK) at frequency above 1GHz. The resolution bandwidth of test receiver/spectrum analyzer is 1 MHz for Average detection (AV) at frequency above 1GHz.

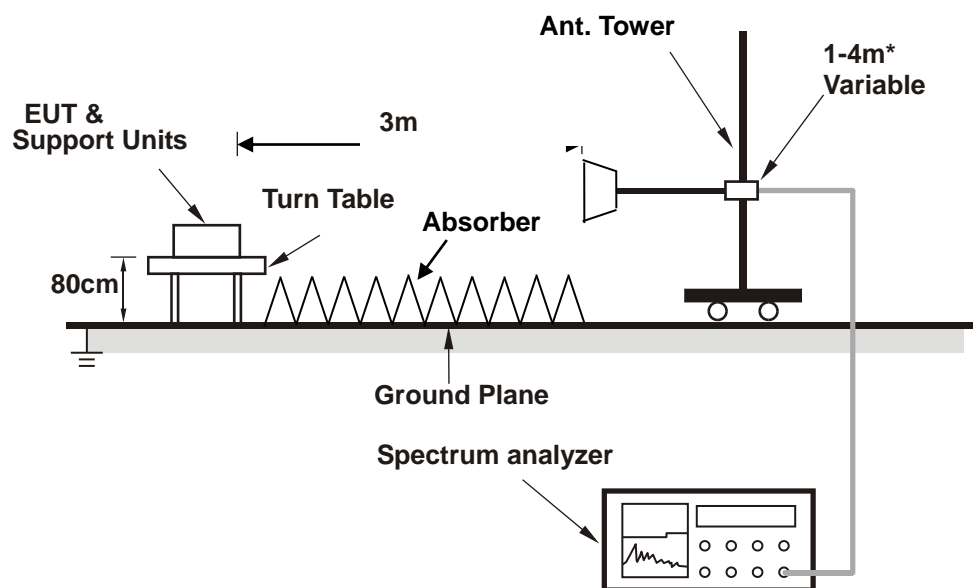

* :depends on the EUT height and the antenna 3dB beamwidth both.

For the actual test configuration, please refer to the related item – Photographs of the Test Configuration.

7.4 Test Results

Frequency Range	1GHz ~ 16GHz	Detector Function & Resolution Bandwidth	Peak (PK) / Average (AV), 1MHz
Input Power	120Vac, 60Hz	Environmental Conditions	25°C, 63%RH
Tested By	Adam Chen	Test Date	2020/9/2
Test Mode	Mode 1		

Antenna Polarity & Test Distance : Horizontal at 3 m

No	Frequency (MHz)	Emission Level (dBuV/m)	Limit (dBuV/m)	Margin (dB)	Antenna Height (m)	Table Angle (Degree)	Raw Value (dBuV)	Correction Factor (dB/m)
1	1387.36	53.48 PK	80.00	-26.52	1.39 H	172	75.68	-22.20
2	1387.36	47.22 AV	60.00	-12.78	1.39 H	172	69.42	-22.20
3	1541.48	57.36 PK	80.00	-22.64	1.24 H	170	79.18	-21.82
4	1541.48	49.08 AV	60.00	-10.92	1.24 H	170	70.90	-21.82
5	2312.19	54.58 PK	80.00	-25.42	1.59 H	246	73.79	-19.21
6	2312.19	39.17 AV	60.00	-20.83	1.59 H	246	58.38	-19.21

Remarks:

1. Emission Level(dBuV/m) = Raw Value(dBuV) + Correction Factor(dB/m)
2. Correction Factor(dB/m) = Antenna Factor (dB/m) + Cable Factor (dB) – Pre-Amplifier Factor (dB)
3. The other emission levels were very low against the limit.
4. Margin value = Emission level – Limit value

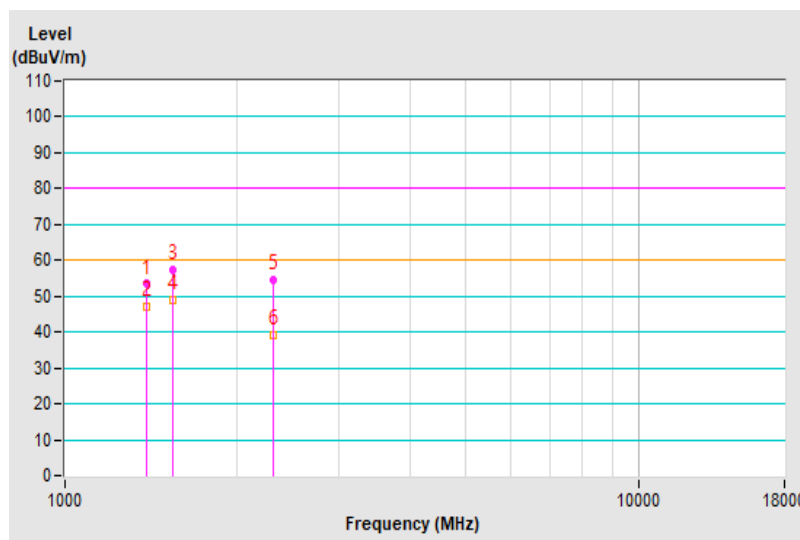

Frequency Range	1GHz ~ 16GHz	Detector Function & Resolution Bandwidth	Peak (PK) / Average (AV), 1MHz
Input Power	120Vac, 60Hz	Environmental Conditions	25°C, 63%RH
Tested By	Adam Chen	Test Date	2020/9/2
Test Mode	Mode 1		

Antenna Polarity & Test Distance : Vertical at 3 m								
No	Frequency (MHz)	Emission Level (dBuV/m)	Limit (dBuV/m)	Margin (dB)	Antenna Height (m)	Table Angle (Degree)	Raw Value (dBuV)	Correction Factor (dB/m)
1	1387.35	51.52 PK	80.00	-28.48	1.00 V	237	73.72	-22.20
2	1387.35	44.30 AV	60.00	-15.70	1.00 V	237	66.50	-22.20
3	1541.52	60.23 PK	80.00	-19.77	1.94 V	248	82.05	-21.82
4	1541.52	52.34 AV	60.00	-7.66	1.94 V	248	74.16	-21.82
5	2312.29	56.41 PK	80.00	-23.59	2.12 V	220	75.62	-19.21
6	2312.29	43.70 AV	60.00	-16.30	2.12 V	220	62.91	-19.21

Remarks:

1. Emission Level(dBuV/m) = Raw Value(dBuV) + Correction Factor(dB/m)
2. Correction Factor(dB/m) = Antenna Factor (dB/m) + Cable Factor (dB) – Pre-Amplifier Factor (dB)
3. The other emission levels were very low against the limit.
4. Margin value = Emission level – Limit value

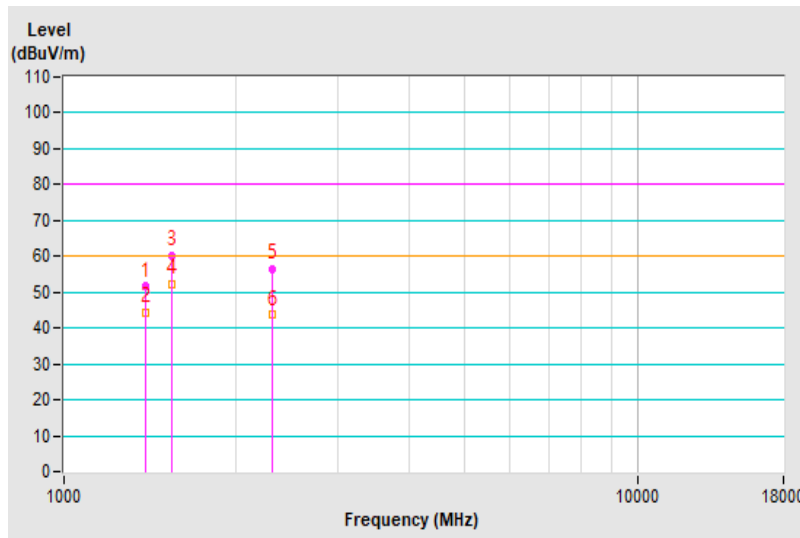

8 Pictures of Test Arrangements

8.1 Conducted Emissions at Mains Ports

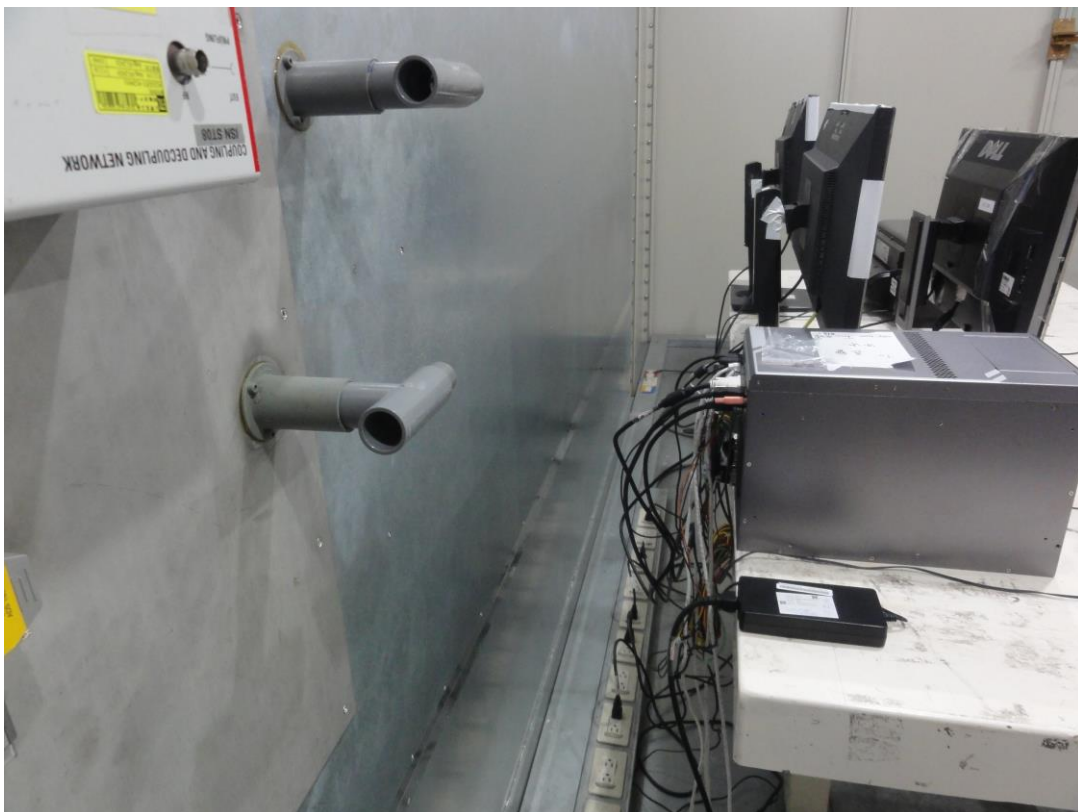

8.2 Radiated Emissions up to 1 GHz



8.3 Radiated Emissions above 1 GHz

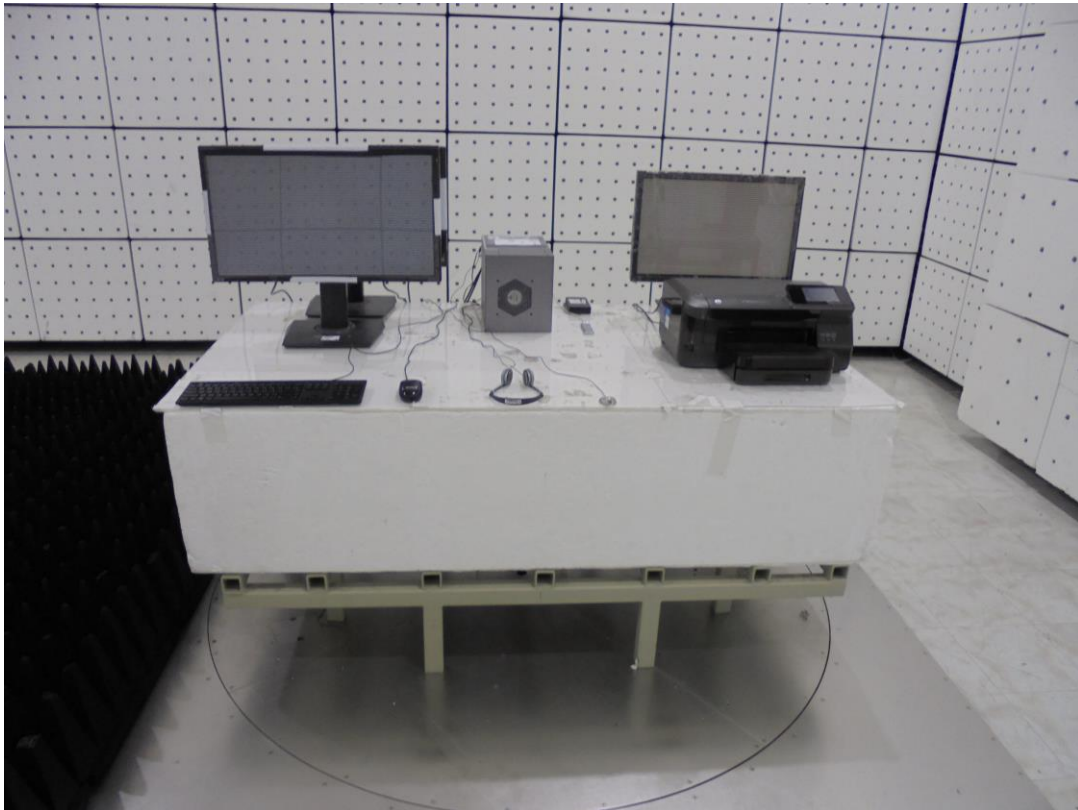

Appendix – Information of the Testing Laboratories

We, Bureau Veritas Consumer Products Services (H.K.) Ltd., Taoyuan Branch, were founded in 1988 to provide our best service in EMC, Radio, Telecom and Safety consultation. Our laboratories are FCC recognized accredited test firms and accredited according to ISO/IEC 17025.

If you have any comments, please feel free to contact us at the following:

Lin Kou EMC/RF Lab

Tel: 886-2-26052180

Fax: 886-2-26051924

Hsin Chu EMC/RF/Telecom Lab

Tel: 886-3-6668565

Fax: 886-3-6668323

Hwa Ya EMC/RF/Safety Lab

Tel: 886-3-3183232

Fax: 886-3-3270892

Email: service.adt@tw.bureauveritas.com

Web Site: www.bureauveritas-adt.com

The address and road map of all our labs can be found in our web site also.

--- END ---